

soundblox[®] 2

DIMENSION REVERB USER'S GUIDE

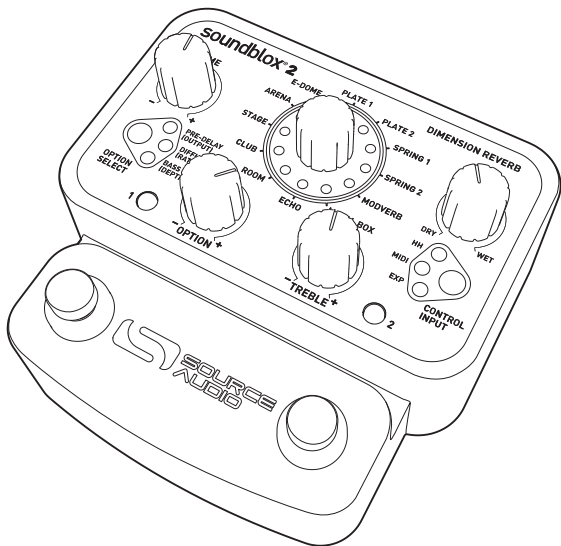

WELCOME

Thank you for purchasing the Soundblox 2 Dimension Reverb. The Dimension Reverb features a broad set of painstakingly crafted professional quality reverb effects including models of popular mechanical reverbs, acoustical reverbs, and our own original effect creations. Each reverb effect can be customized and tweaked by a full set of useful controls and additional interface options.

The Dimension Reverb also features a new compact physical format in addition to many new and useful features designed for easy on-stage use. Like all Soundblox effects pedals, the Soundblox 2 Dimension Reverb is also “Hot Hand Ready”.

The Quick Start guide will help you with the basics. For more in-depth information about the Dimension Reverb, move on to the following sections.

Enjoy!

-The Source Audio team



If possible, dispose of the device at a recycling center. Do not dispose of the device with the household waste.

For full compliance with EN 61000-4-6 standard, input cable must be less than 3 meters in length.

OVERVIEW

DIVERSE SOUND PALETTE

12 unique, rich-sounding reverb effects based on physical spaces and mechanical reverbs.

DEEP CONTROL SET

Access to Reverb control parameters typically found only on professional rack systems.

STATE-OF-THE-ART DSP

Our proprietary 56-bit Digital Signal Processor, the SA601, and crystal clear 24-bit converters.

COMPACT DESIGN

A compact, rugged, cast-aluminum housing.

UNIVERSAL BYPASS™

Select either analog buffered or relay-based True Bypass.

2 USER PRESETS

Easy to configure user presets selectable via two footswitches.

MULTI-FUNCTION INPUT

A multi-purpose control input for use with Hot Hand®, expression pedal, or MIDI.

QUICK START

1. POWER

To power the unit, connect the included DC adapter power supply to the 9V DC jack on the back panel.

Note: Using a non-Source Audio supply could damage the unit. Please be very cautious when using 3rd party power supplies.

2. GUITAR/AUDIO CONNECTIONS

Next, plug your guitar (or other instrument) into the jack labeled GUITAR IN via a standard ¼" cable. Connect your amp (or other audio device) to the GUITAR OUT jack, again with a standard ¼" cable. Both input and output are mono signals.

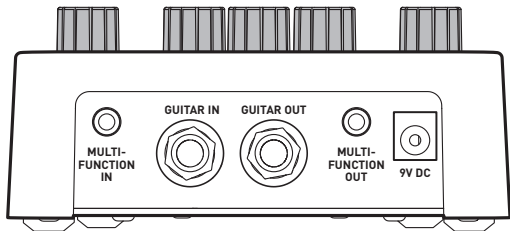

3. BRIEF KNOB, FOOTSWITCH, AND BUTTON DESCRIPTIONS

[see *Controls* section for more details]

- **EFFECT KNOB:** selects the reverb type to be used.
- **TIME:** adjusts the duration of the reverb.
- **OPTION:** adjusts parameter selected by the OPTION SELECT button.
- **TREBLE:** controls the high frequency damping on the reverb.
- **MIX:** balances the wet and dry signals.
- **OPTION SELECT:** selects which parameter will be controlled by the OPTION knob.
- **CONTROL INPUT:** selects the external controller type to be used.
- **FOOTSWITCHES:** Enables/Disables a preset depending on the selected footswitch. Press and hold to save an edited preset.

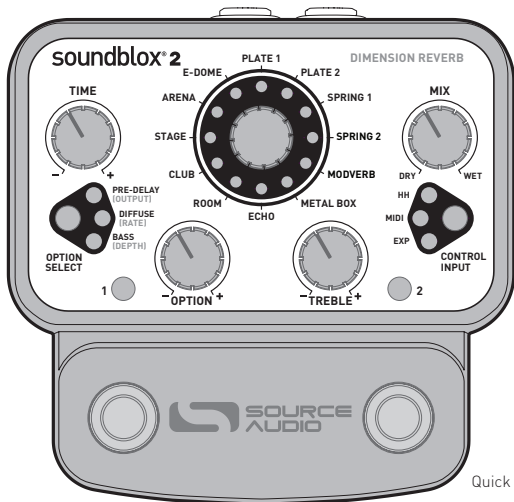

THEORY OF OPERATION

For those readers interested in seeing exactly what's happening inside the Dimension Reverb, figure 1 is a block diagram of the reverb algorithm. The various control knobs are positioned next to the processing steps they control.

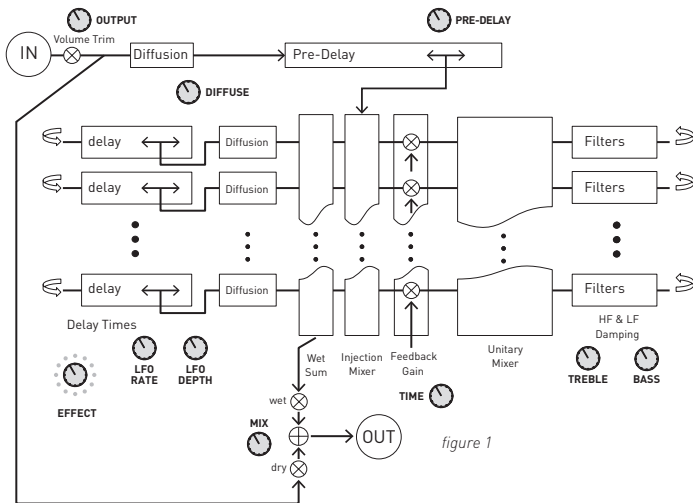

figure 1

Looking at the diagram of the algorithm, the input audio signal comes in initially and goes through a volume control and a diffusion block (controlled by DIFFUSE) before entering the pre-delay line. The length of that delay is set with the PRE-DELAY control. The output of that delay is sent into the main reverb loop through the injection mixer. The audio circulates through the main reverb loop consisting of a number of delay lines with their lengths set by the EFFECT knob. The precise lengths of these delay lines are varied by an LFO (Low Frequency Oscillator) controlled by the RATE and DEPTH.

These delay outputs go into additional diffusers (also controlled by DIFFUSE), then to a block that creates the final wet signal, then to the injection mixer, and then to the feedback block. The reverb TIME knob sets the amount of feedback through the loop anywhere from 0.0 (minimum time) to 0.993 (maximum time). The higher the feedback, the longer the sound will continue to circulate through the entire reverb loop. Lower feedback will make the output signal die away more quickly.

The Unitary Mixer takes all these signals and combines them to produce the same number of output signals. However, this mixer has special properties, such that the signal energy leaving the mixer is exactly equal to the energy going in. This is an important feature that keeps the signal from ringing excessively at any given frequency. Next there is a bank of filters that control the high and low frequency damping. The amount of damping is set by the TREBLE and BASS controls. At this point the signal flow wraps around back into the delay lines. Meanwhile, the extracted wet signal is combined with the dry signal (controlled by the MIX knob) and this becomes the final output.

CONNECTIONS

GIUITAR IN: Connect your guitar, bass, or other instrument here using a standard MONO ¼" cable.

GIUITAR OUT: Connect this to your amp, pedal, or other audio device.

MULTI-FUNCTION IN (optional): The multi-function input is a flexible control input for use with external controllers. It can accept digital or analog signals which allows the Dimension Reverb to interface with the following accessories:

- SA110/SA115 Hot Hand Wireless Adapter
- SA111 Hot Hand Wired Sensor
- SA161 Source Audio Dual Expression Pedal
- Source Audio Soundblox 2 MIDI Adapter

MULTI-FUNCTION OUT (optional): Use a Source Audio daisy-chain cable to connect this jack to the sensor/multi-function input of another Soundblox pedal.

9V DC: Connect the included 9 Volt DC power supply here.

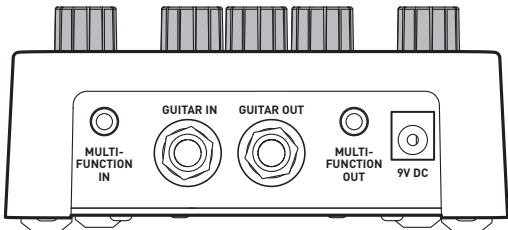

CONTROLS: KNOBS

EFFECT (not labeled)

The effect knob selects which reverb type will be used. There are 12 positions around the knob. For information on the individual settings see the *Effect Types* section.

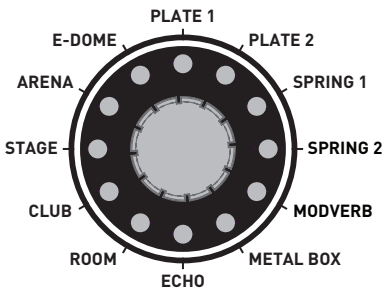

- Continued



TIME

This is the primary reverb control. The TIME parameter sets how long the reverb sound will “ring out”. This can also be thought of as a feedback control to set how long the input will circulate through the reverb effect before dying away. The minimum time corresponds to zero feedback within the reverb. This will produce a single echo spread out by the difference in times of the various delay lines inside the reverb. The shortest times are not realistic in a traditional reverb sense and the longest times are extreme, but each can produce some very interesting effects.



OPTION

The OPTION knob offers six secondary parameters that can be assigned to a single physical knob. Press the OPTION SELECT button to scroll through the parameters. The knob will adjust the parameter that is currently selected by the OPTION SELECT button:

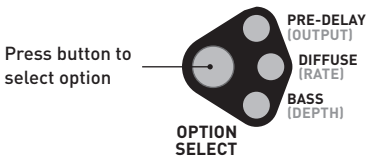

- **PRE-DELAY (green LED):** Sets the initial time before the reverb begins. Pre-delay times vary between 0 and .5 seconds. In ECHO mode delay times vary between 0 and 2.5 seconds. Pre-delay is excellent for creating slapback effects. It will also create the illusion of playing in a larger space (the longer it takes to hear the first echo, the further away the walls would be). Long pre-delay times may seem excessive, but can work well in a band or mix context.

Tip: Use pre-delay to add clarity. If the reverb begins too soon after a note is played, it tends to clutter the perception of the sound. Delaying the reverb makes it much easier to hear the dry signal without sacrificing any of the reverb signal. Also, try using pre-delay with a very short reverb time for an interesting and non-traditional effect. This combination creates a single, heavily processed echo.

Tip: If the pre-delay knob is moved while audio is running through the effect, a Doppler shift will be heard. Assigning an expression pedal or Hot Hand to the Pre-Delay knob (See the *Control Assign* section) is a great way to create some extremely far-out effects.

- **OUTPUT (red LED):** Sets the overall output volume of the effect which is useful for matching the level of the effect vs. the bypass volume. It can also be used to prevent clipping if longer reverb times are used with continuous loud inputs.
- **DIFFUSE (green LED):** Adjusts the amount of “spreading” in the feedback loop. The higher this parameter is set, the more the sound will be diffused as it circulates in the reverb loop. Sharp transients (like guitar pick noise) will be smeared out over time. At least a small amount of diffusion is recommended to create natural sounding reverbs. Larger amounts can smooth over what might otherwise be an undesirable set of individual early echoes. However, maximum diffusion may produce some ringing at certain frequencies.
- **RATE (red LED):** Adjusts the rate of the LFO (Low Frequency Oscillator) that is applied to the reverb. The modulation is an optional setting that adds some nice animation to the reverb sound. In the physical world, reverb modulation would be the sound created in a room with moving walls. Obviously, real rooms don't have moving walls, but they do have moving air currents, and also a complexity of reverberation paths way beyond what we can simulate. With a slow rate and low depth setting the LFO provides an added level of realism to our reverb.
- **BASS (green LED):** Like the TREBLE control, the BASS parameter works like a bass tone control by damping the amount of bass frequencies that go through the feedback loop. Set to full counter-clockwise, this is most bass damping which will tend to cut the overall bass tone. Full clockwise will allow the bass frequencies to ring out resulting in more overall bass.

- **DEPTH (red LED):** The second control related to the LFO. The DEPTH control adjusts the total amount of modulation applied to the reverb. As the depth is turned up, there is a sense that the wet signal is running through a chorus effect. With more depth, pitch shifts on individual echoes may be heard and things get rather unnatural (but what's wrong with that?).

Factory Defaults: given the number of different functions available on the OPTION KNOB, it can be useful to “zero” all of the controls to a default value. We pre-loaded the Dimension Reverb with unique default settings for each reverb type which are a good starting point for each reverb sound. You can recall these values at any time by pressing and holding the OPTION SELECT button until the six red and green LEDs begin to blink.



MIX

Adjusts the balance of the wet reverb sound and the clean input signal. Full counter-clockwise is a completely dry tone and full clockwise is the effected tone with no dry signal added.

- Continued



TREBLE

This knob controls the high frequency damping (or roll-off) in the feedback loop. As the knob is turned down (full counter-clockwise) and more damping is applied, higher frequencies will tend to die out more quickly for a duller sound. Turn the knob fully clockwise for the least amount of damping which will result in more overall treble in the sound.

Discovering Preset Knob Positions

Since the Dimension Reverb preset values can differ from the physical knob positions, it may be useful to determine the positions of the preset knob values. To do this, start with the pedal in bypass and set all of the knobs to the full counter-clockwise position. Next, enable the preset and slowly turn each knob up one at a time until the preset indicator LED begins to blink rapidly. When this happens, the current position of the knob matches the saved value.

CONTROLS: FOOTSWITCHES

There are two footswitches on the Dimension Reverb. The left footswitch corresponds to preset 1 and the right footswitch corresponds to preset 2. Pressing either of the footswitches will engage the respective preset. Pressing the same footswitch again will put the effect back into bypass mode. Pressing the other footswitch will engage the other preset without going into bypass. There are indicator LEDs for each footswitch that show which preset is currently enabled or both LEDs will be off when the effect is in bypass mode.

When a preset is enabled and edited, the indicator LED for that preset will begin to blink occasionally to show that the preset has been edited. Once a preset has been edited, it can be saved by pressing and holding the footswitch. The LED will blink quickly to indicate that the preset has been saved. Once changes are saved, the LED will be lit solidly again.

Note: Changes made to a preset will be lost if you go into bypass or switch to another preset without saving.

An edited preset can be saved to either of the two preset locations. For example if preset 1 has been selected and edited, it can be saved to preset location 2 by pressing and holding the right footswitch.

EFFECT TYPES

Here are some brief descriptions of the EFFECT knob settings on the Soundblox 2 Dimension Reverb:

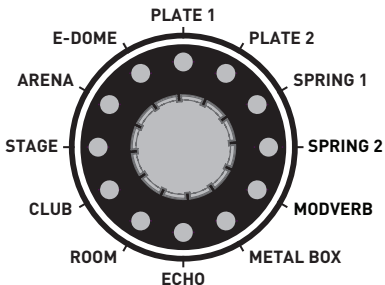

ROOM SOUNDS

The first five EFFECT choices are intended to represent real acoustical spaces progressing in size from small to enormous. The room sounds are labeled: Room, Club, Stage, Arena, and E-Dome.

PLATE AND SPRING REVERBS

Our Plate and Spring effects are simulations of two popular mechanically constructible reverb units. The critical component in a real plate reverb is large plate of sheet metal. Plate reverbs tend to have a high diffusion rate, so for an accurate representation the DIFFUSE knob should be on the high side.

The Spring Reverbs simulate the effect of broadcasting a signal into an actual coiled metal spring. Spring reverbs are commonly found built into many guitar amplifiers.

MODVERB

All of the reverbs have LFO modulation applied to the delay line lengths, but ModVerb has delay lines nearly as long as the E-Dome delays and an additional modulation in which the internal wiring of the reverb smoothly changes at the LFO rate.

METAL BOX

This reverb type also has extra modulation. It replicates a very small space, perhaps the size of a metal cargo-shipping container. It will give a sort of chorused sound with very short reverb times and a lot of modulation.

ECHO

This a basic delay algorithm, using all the same controls that the reverbs use. The TIME knob sets the feedback amount, while the PRE-DELAY sets the echo time. Add some diffusion to create more interesting delay effects.

EXTERNAL CONTROL

One of the new Core Features of the Soundblox 2 line of effects pedals is the addition of the Multi-Function Input. The Multi-Function input is an intelligent control input that can accept both digital and analog control signals. The Multi-Function input replaces the Sensor Input on previous Soundblox pedals. The MULTI-FUNCTION input can connect to wired or wireless Hot Hand accessories, a Source Audio Expression Pedal, or a future Source Audio MIDI interface that will enable full MIDI I/O access to the pedal.

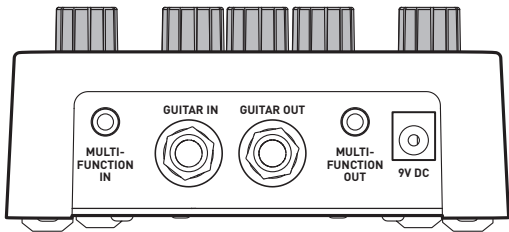

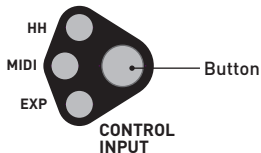

Selecting an external control input:

Press the CONTROL INPUT button to cycle between the external control options. There are four possible settings:

- **OFF (no LEDs on):** External control is disabled in this mode
- **EXP:** Expression Pedal for use with the SA161 Source Audio Dual Expression Pedal. By default, the expression pedal will control the TIME parameter. The expression pedal can also be assigned to control any other knob parameter or the REVERB SEND parameter (see below).
- **MIDI:** MIDI control mode. Select to enable MIDI I/O through the Soundblox 2 MIDI Interface
- **HH:** Hot Hand mode. Select to enable Hot Hand control. By default, Hot Hand will be assigned to control the TIME parameter. Alternatively, Hot hand can also be assigned to control any other knob parameter or the REVERB SEND.

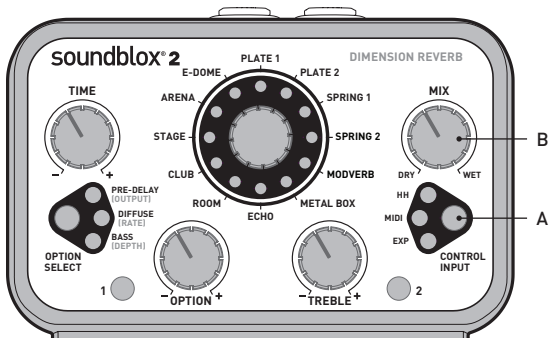

CONTROL ASSIGN

By default, the expression pedal and Hot Hand inputs are assigned to control the TIME parameter. This can easily be changed to control any other knob parameter or an additional REVERB SEND parameter. To assign control to a knob parameter:

1. Select the desired external control option: EXP for expression pedal, HH for Hot Hand.
2. Press and hold the CONTROL INPUT (A) button until the LED begins to blink slowly.
3. Set the low position of the desired knob, for example MIX (B), to the lowest setting you would like to use.
4. Press the CONTROL INPUT button again and the LED will now blink rapidly.
5. Set the desired high position you would like to use.
6. Press the CONTROL INPUT button to complete the assignment. The LED will blink 3 times to indicate the process is complete.

Note: Different control assignments can be used for each preset. Don't forget to save your settings!

REVERB SEND PARAMETER

There is an additional parameter that does not have a knob associated with it but can be used with the expression pedal input or with Hot Hand.

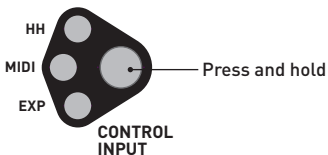

To select REVERB SEND as the assigned parameter for external control, set the CONTROL INPUT to OFF (no LEDs lit). Press and hold the CONTROL INPUT button until all three LEDs blink rapidly. The REVERB SEND is now selected as the parameter to be externally controlled. Next, select either HH or EXP mode to control the REVERB SEND.

The REVERB SEND controls how much of the guitar input will be sent in to the reverb effect and how much will be sent to the output. In some ways, this is similar to the MIX control. However, there is an important difference in that this control comes *before* the reverb. By using the REVERB SEND you can selectively send some input signal to the reverb and bypass the reverb for other input. This allows you to create sounds that will ring out and sustain with the REVERB SEND on. When the REVERB SEND is turned down, the sound of the reverb will continue to circulate while a dry sound can be played over it. The following example will help explain:

- *Continued*

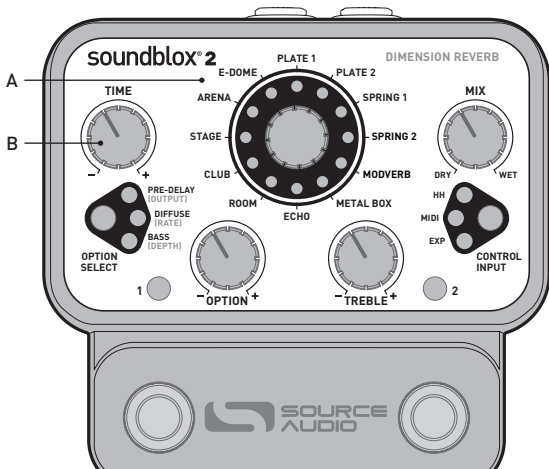

1. Select the expression pedal input and assign it to REVERB SEND as described above.
2. Select a desired reverb type (ex. ARENA) (A) and turn up the TIME (B) knob to create a long tailing and sustained effect.
3. Put the expression pedal in toe down position and play into the effect. The sound will now begin to reverberate.
4. Next, move the expression pedal into the heel down position to turn down the REVERB SEND.
5. Now play again and the input will stay dry and not go into the reverb effect.

This control allows for some fun ambient effects where a background sound can be created and maintained while a separate part can be played along without turning the entire output into mush.

Using the REVERB SEND for bypass trailing

A common problem when bypassing reverb and delay effects is that the trailing sound is lost. When the REVERB SEND is assigned to the Expression Pedal, it can also be used as a “soft” bypass. With the expression pedal in the toe down position, the reverb will be fully engaged. By moving to the expression pedal to the heel down position, this will effectively bypass the effect but allow the reverb to trail off.

MIDI CONTROL

The Dimension Reverb can be controlled via generic MIDI messages. To access MIDI functionality, the pedal requires the Source Audio Neuro Hub (sold separately - please check www.sourceaudio.net for availability). The Hub expands your connections to further the control of up to five Soundblox2 or Ones Series pedals. The Hub has 5-pin MIDI DIN In and Out jacks, a USB port, Sensor In (for Hot Hand) and a 1/4” expression input.

Save up to 128 multi pedal presets (or “scenes”) complete with assigned expression control. Easily recall complex presets with a single MIDI program change messages. The Hub also receives MIDI clock or continuous controller (CC) messages.

For more information on using your Soundblox 2 pedals with MIDI, and for MIDI mappings, please visit our website at www.sourceaudio.net

USE WITH HOT HAND

All Soundblox pedals are compatible with our Hot Hand accessories. Hot Hand units consist of a ring mounted accelerometer that is used to detect motion for controlling effect parameters. On the Dimension Reverb, a Hot Hand unit can be connected to the Multi-Function input. To enable Hot Hand, select the HH mode as the external control option. This will take the input signals for the Hot Hand unit and use them to control whichever parameter has been assigned.

The Dimension Reverb can also be calibrated to change the midpoint of the Hot Hand control range. To do this, follow the calibration procedure below. Note that calibration is only used for Hot Hand mode and calibration is NOT required before use.

To perform a calibration:

1. Select a preset by pressing a footswitch.
2. Enable Hot Hand control by selecting HH mode from the external controls.
3. Press and hold the CONTROL INPUT button until the HH red LED begins to blink slowly (this is the same as the control assign procedure).
4. Put the Hot Hand sensor into the desired calibration position.
5. Press the footswitch for the currently selected preset.
6. The HH LED will blink when the calibration is complete.

If you have trouble with calibration and need to get back to the default setting, place the sensor on a flat, level surface with the blue LED facing down and run the calibration procedure again.

UNIVERSAL BYPASS™

Another added feature in the Soundblox 2 line is Universal Bypass which allows you to select between buffered and relay-based true bypass. In other effects pedals, both traditional bypass methods have pros and cons associated with them. Active analog bypass (or buffered) provides a consistent input impedance so that if the input is susceptible (like a guitar pickup) to variations in input impedance there won't be any noticeable change in tone. Buffered bypass is typically quieter and less prone to clicks and pops. True bypass has the benefit of providing a dedicated hardware bypass signal path; however, it can cause clicks/pops and typically requires a mechanically complex 3P3T (3-pole, 3-throw) switch.

Relay-based true bypass is a better option but can cause tonal variations since the input impedance can vary when the effect is engaged vs. bypassed.

Ideally, the first pedal in a signal chain should be a buffered input followed by true bypass in the rest of the signal chain.

The Soundblox 2 line introduces Universal Bypass™ as the solution to this problem. Each Soundblox 2 pedal can be configured to either buffered or relay-based true bypass modes, depending on what is needed in a pedal signal chain.

By default, the Soundblox 2 Dimension Reverb is set to use the relay-based true bypass. To switch to buffered bypass press and hold the right footswitch when powering up the pedal. Continue to hold the footswitch until the footswitch LED blink slowly 3 times. The pedal is now in buffered bypass. To switch back to true bypass, repeat the same process with the left footswitch.

SPECIFICATIONS

Dimensions

- L: 4.5 inches
- W: 4.5 inches
- H: 2.25 inches (including knobs)

Weight

- 1.00 lbs

Power

- 140mA @ 9V DC (max 180mA with Hot Hand Wireless Adapter)
- Negative tip power jack

Audio Performance

- Maximum input level: 2.0 Vrms (+6 dBV)
- Input impedance: 1 M Ω m
- Output impedance: 1 k Ω m
- 115dB DNR audio path
- 24-bit audio conversion
- 56-bit digital data path
- Universal Bypass™ (buffered or relay-based true bypass)

TROUBLESHOOTING

Noise:

Power Source	Ensure that the proper power supply is being used.
Near noise source	Move pedal away from power supplies and other equipment.
Other equipment	Remove other effects from signal chain, see if noise persists.
Bad cables	Swap out audio cables.

Hot Hand doesn't work:

Low power	Ensure that the proper power supply is being used.
Not calibrated properly	Calibrate the Hot Hand — see page 24.
Not connected properly	Check Hot Hand connections.

Unit appears dead/no LEDs lit:

Wrong power supply	Use correct power supply as defined on page 4.
Input plug not connected	Ensure that input cable is connected to the GUITAR input.
Corroded input cable plug	Check input cable plug for corrosion on sleeve, swap out cable if necessary.

LIMITED WARRANTY

Source Audio, LLC (hereinafter "Source Audio") warrants that your new Source Audio Soundblox 2 Dimension Reverb, when purchased at an authorized Source Audio dealer in the United States of America ("USA"), shall be free from defects in materials and workmanship under normal use for a period of two (2) years from the date of purchase by the original purchaser. This Limited Warranty does not extend to the batteries which are purchased as is. Please contact your dealer for information on warranty and service outside of the USA.

Under this Limited Warranty, Source Audio's sole obligation and the purchaser's sole remedy shall be repair, replacement, or upgrade, at Source Audio's sole discretion, of any product that, if properly used and maintained, proves to be defective upon inspection by Source Audio. Source Audio reserves the right to update any unit returned for repair and to change or to improve the design of the product at any time without notice. Source Audio reserves the right to use reconditioned parts and assemblies as warranty replacements for authorized repairs. Any product repaired, replaced, or upgraded pursuant to this Limited Warranty will be warranted for the remainder of the original warranty period.

This Limited Warranty is extended to the original retail purchaser. This Limited Warranty can be transferred to anyone who may subsequently purchase this product provided that such transfer is made within the applicable warranty period and Source Audio is provided with all of the following information: (i) all warranty registration information (as set forth on the registration card) for the new owner, (ii) proof of the transfer, within thirty (30) days of the transfer, and (iii) a photocopy of the original sales receipt. Warranty coverage shall be determined by Source Audio in its sole discretion. This is your sole warranty. Source Audio does not authorize any third party, including any dealer or sales representative, to assume any liability on behalf of Source Audio or to make any warranty on behalf of Source Audio.

WARRANTY INFORMATION

Source Audio may, at its option, require proof of the original purchase date in the form of a dated copy of original authorized dealer's invoice or sales receipt. Service and repairs of Source Audio products are to be performed only at the Source Audio factory or a Source Audio authorized service center. Prior to service or repair under this Limited Warranty, the purchaser must request from Source Audio a return authorization, which is available at:

Source Audio LLC
120 Cummings Park, Woburn, MA 01801
(781) 932-8080 or at www.sourceaudio.net.

Unauthorized service, repair, or modification will void this Limited Warranty.

DISCLAIMER AND LIMITATION OF WARRANTY

DO NOT OPEN THE EFFECTS PEDAL UNDER ANY CIRCUMSTANCE. THIS WILL VOID THE WARRANTY.

THE FOREGOING LIMITED WARRANTY IS THE ONLY WARRANTY GIVEN BY SOURCE AUDIO AND IS IN LIEU OF ALL OTHER WARRANTIES. ALL IMPLIED WARRANTIES, INCLUDING WARRANTIES OF MERCHANTABILITY AND FITNESS FOR ANY PARTICULAR PURPOSE, EXCEEDING THE SPECIFIC PROVISIONS OF THIS LIMITED WARRANTY ARE HEREBY DISCLAIMED AND EXCLUDED FROM THIS LIMITED WARRANTY. UPON EXPIRATION OF THE APPLICABLE EXPRESS WARRANTY PERIOD, SOURCE AUDIO SHALL HAVE NO FURTHER WARRANTY OBLIGATION OF ANY KIND, EXPRESS OR IMPLIED. SOURCE AUDIO SHALL IN NO EVENT BE LIABLE FOR ANY SPECIAL, INCIDENTAL OR CONSEQUENTIAL DAMAGES SUFFERED BY THE PURCHASER OR ANY THIRD PARTY, INCLUDING WITHOUT LIMITATION, DAMAGES FOR LOSS OF PROFITS OR BUSINESS OR DAMAGES RESULTING FROM USE OR PERFORMANCE OF THE PRODUCT, WHETHER IN CONTRACT OR IN TORT. SOURCE AUDIO SHALL NOT BE LIABLE FOR ANY EXPENSES, CLAIMS OR SUITS ARISING OUT OF OR RELATING TO ANY OF THE FOREGOING. Some states do not allow the exclusion or limitation of implied warranties so some of the above limitations and exclusions may not apply to you. This Limited Warranty gives you specific legal rights, and you may also have other rights, which vary, from state to state. This Limited Warranty only applies to products sold and used in the USA. Source Audio shall not be liable for damages or loss resulting from the negligent or intentional acts of the shipper or its contracted affiliates. You should contact the shipper for proper claims procedures in the event of damage or loss resulting from shipment.

